

Fig. 7-20—Voltage-multiplying circuits with one side of transformer secondary grounded. (A) Voltage doubler (B) Voltage tripler (C) Voltage quadrupler.

Capacitances are typically 20 to 50 $\mu\text{f.}$, depending upon output current demand. D.c. ratings of capacitors are related to E_{peak} ($1.4 E_{\text{ac}}$):

- C_1 —Greater than E_{peak}
- C_2 —Greater than $2E_{\text{peak}}$
- C_3, C_4 —Greater than $4E_{\text{peak}}$

A voltage-tripling circuit is shown in Fig. 7-20B. On one half of the a.c. cycle C_1 is charged to the source voltage through the left-hand rectifier. On the opposite half of the cycle the middle rectifier conducts and C_2 is charged to twice the source voltage, because it sees the transformer plus the charge in C_1 as the source. At the same time the right-hand rectifier conducts and, with the transformer and the charge in C_2 as the source, C_3 is charged to three times the transformer voltage. The - side of the output can be grounded if the polarities of all of the capacitors and rectifiers are reversed.

The voltage-quadrupling circuit of Fig. 7-20C works in substantially similar fashion.

In any of the circuits of Fig. 7-20, the output voltage will approach an exact multiple (2, 3 or 4, depending upon the circuit) of the peak a.c. voltage when the output current drain is low and the capacitance values are high.

of the a.c. cycle; the other rectifier is nonconductive during this time. During the other half of the cycle the right-hand rectifier conducts and C_2 becomes charged; they see as the source the transformer plus the voltage in C_1 . By reversing the polarities of the capacitors and rectifiers, the - side of the output can be grounded.

VOLTAGE STABILIZATION

Gaseous Regulator Tubes

There is frequent need for maintaining the voltage applied to a low-voltage low-current circuit at a practically constant value, regardless of the voltage regulation of the power supply or variations in load current. In such applications, gaseous regulator tubes (0C3/VR105, 0D3/VR150, etc.) can be used to good advantage. The voltage drop across such tubes is constant over a moderately wide current range. Tubes are available for regulated voltages near 150, 105, 90 and 75 volts.

The fundamental circuit for a gaseous regulator is shown in Fig. 7-21A. The tube is connected in series with a limiting resistor, R_1 , across a source of voltage that must be higher than the starting voltage. The starting voltage is about 30 to 40 per cent higher than the operating voltage. The load is connected in parallel

with the tube. For stable operation, a minimum tube current of 5 to 10 ma. is required. The maximum permissible current with most types is 40 ma.; consequently, the load current cannot exceed 30 to 35 ma. if the voltage is to be stabilized over a range from zero to maximum load current.

The value of the limiting resistor must lie between that which just permits minimum tube current to flow and that which just passes the maximum permissible tube current when there is no load current. The latter value is generally used. It is given by the equation:

$$R = \frac{(E_s - E_r)}{I}$$

where R is the limiting resistance in ohms, E_s is the voltage of the source across which the tube and resistor are connected, E_r is the rated voltage drop across the regulator tube, and I is the maximum tube current in amperes, (usually 40 ma., or 0.04 amp.).

Fig. 7-21B shows how two tubes may be used in series to give a higher regulated voltage than is obtainable with one, and also to give two values of regulated voltage. The limiting resistor may be calculated as above, using the sum of the voltage drops across the two tubes for E_r . Since the upper tube must carry more current than the lower, the load connected to the low-voltage tap must take small current. The total current taken

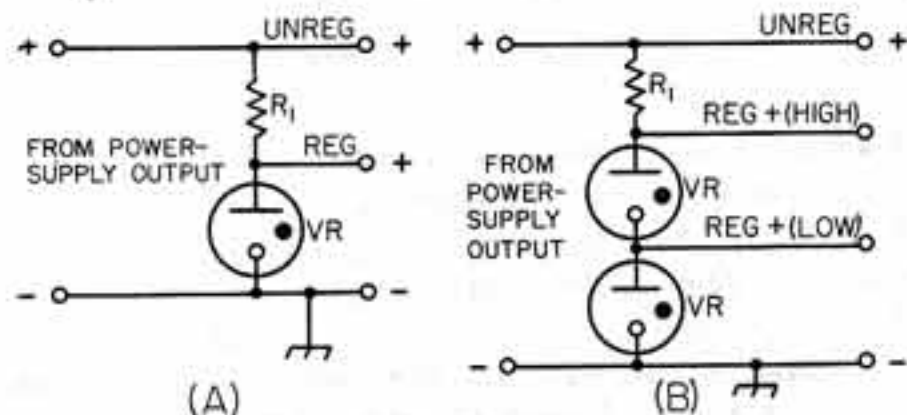

Fig. 7-21—Voltage-stabilizing circuits using VR tubes.

Voltage Stabilization

tain a reduction in ripple voltage adequate for many purposes simply by supplying filtered d.c. to the screens with a consequent saving in weight and cost. The accompanying table shows the performance of the circuit of Fig. 7-23. Column I shows various output voltages, while Column II shows the maximum current that can be drawn at that voltage with negligible variation in output voltage. Column III shows the measured ripple at the maximum current. The second part of the table shows the variation in ripple with load current at 300 volts output.

High-Voltage Regulators

Regulated screen voltage is required for screen-grid tubes used as linear amplifiers in single-side-band operation. Figs. 7-24 through 7-27 show various different circuits for supplying regulated voltages up to 1200 volts or more.

In the circuit of Fig. 7-24, gas-filled regulator tubes are used to establish a fixed reference voltage to which is added an electronically regulated variable voltage. The design can be modified to give any voltage from 225 volts to 1200 volts, with each design-center voltage variable by plus or minus 60 volts.

The output voltage will depend upon the number and voltage ratings of the VR tubes in the string between the 991 and ground. The total VR-tube voltage rating needed can be determined by subtracting 250 volts from the desired output voltage. As examples, if the desired output voltage is 350, the total VR-tube voltage rating should be $350 - 250 = 100$ volts. In this case, a VR-105 would be used. For an output voltage of 1000, the VR-tube voltage rating should be

$1000 - 250 = 750$ volts. In this case, five VR-150s would be used in series.

The maximum voltage output that can be obtained is approximately equal to 0.7 times the r.m.s. voltage of the transformer T_1 . The current rating of the transformer must be somewhat above the load current to take care of the voltage dividers and bleeder resistances.

A single 6L6 will handle 90 ma. For larger currents, 6L6s may be added in parallel.

The heater circuit supplying the 6L6 and 6SJ7 should *not* be grounded. The shaft of R_1 should be grounded. When the output voltage is above 300 or 400, the potentiometer should be provided with an insulating mounting, and should be controlled from the panel by an extension shaft with an insulated coupling and grounded control.

In some cases where the plate transformer has sufficient current-handling capacity, it may be desirable to operate a screen regulator from the plate supply, rather than from a separate supply. This can be done if a regulator tube is used that can take the required voltage drop. In Fig. 7-25, a type 211 or 812A is used, the control tube being a 6AQ5. With an input voltage of 1800 to 2000, an output voltage of 500 to 700 can be

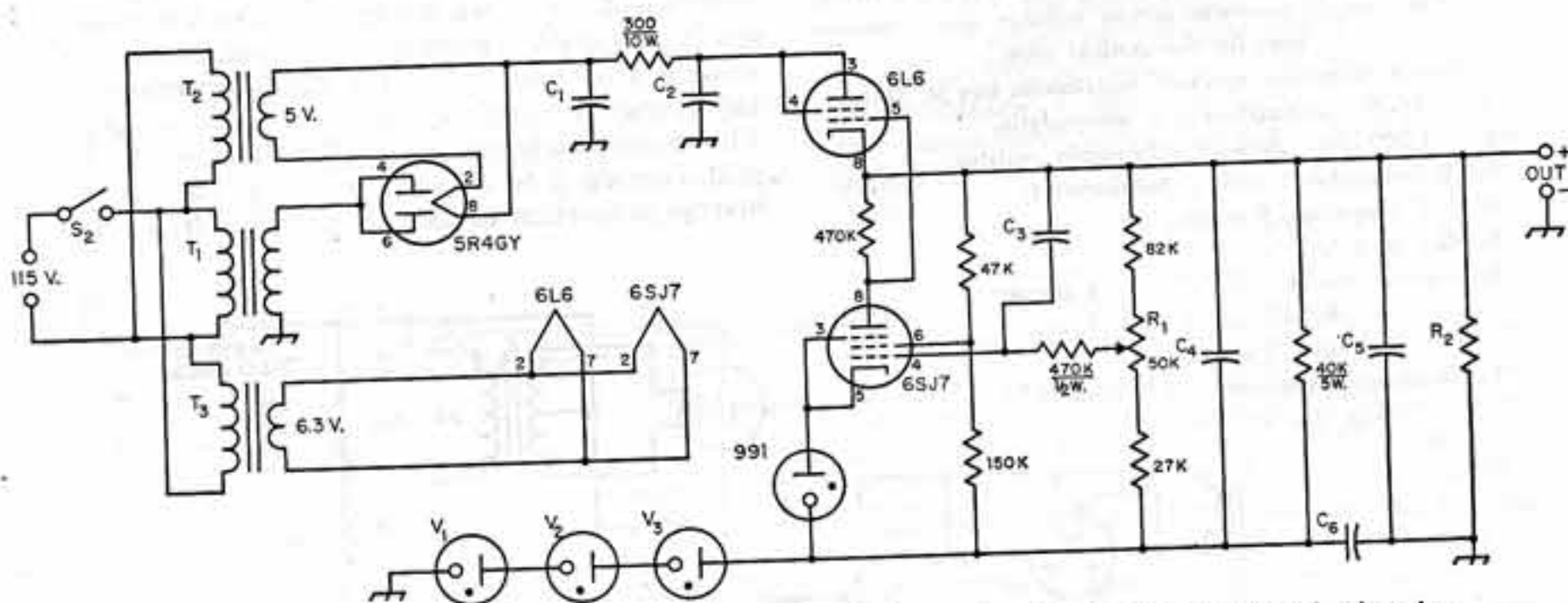

Fig. 7-24—High-voltage regulator circuit by W4PRM. Resistors are 1 watt unless indicated otherwise.

C_1, C_2 —4- μ f. paper, voltage rating above peak-voltage output of T_1 .

C_3 —0.1- μ f. paper, 600 volts.

C_4 —12- μ f. electrolytic, 450 volts.

C_5 —40 μ f., voltage rating above d.c. output voltage.

Can be made up of a combination of electrolytics in series, with equalizing resistor. (See section on ratings of filter components.)

C_6 —4- μ f. paper, voltage rating above voltage rating of VR string.

R_1 —50,000-ohm, 4-watt potentiometer.

R_2 —Bleeder resistor, 50,000 to 100,000 ohms, 25 watts (not needed if equalizing resistors mentioned above are used).

T_1 —See text.

T_2 —Filament transformer; 5 volts, 2 amp.

T_3 —Filament transformer; 6.3 volts, 1.2 amp.

V_1, V_2, V_3 —See text.

Fig. 7-25—Screen regulator circuit designed by W9OKA. Resistances are in ohms ($K = 1000$).

R_1 —6000 ohms for 211; 2300 ohms for 812A, 20 watts.

R_2 —25,000 ohms, 10 watts.

R_3 —Output voltage control, 0.1-megohm, 2-watt potentiometer.

T_1 —Filament transformer: 10 volts, 3.25 amp. for 211; 6.3 volts, 4 amp. for 812A.

T_2 —Filament transformer: 6.3 volts, 1 amp.

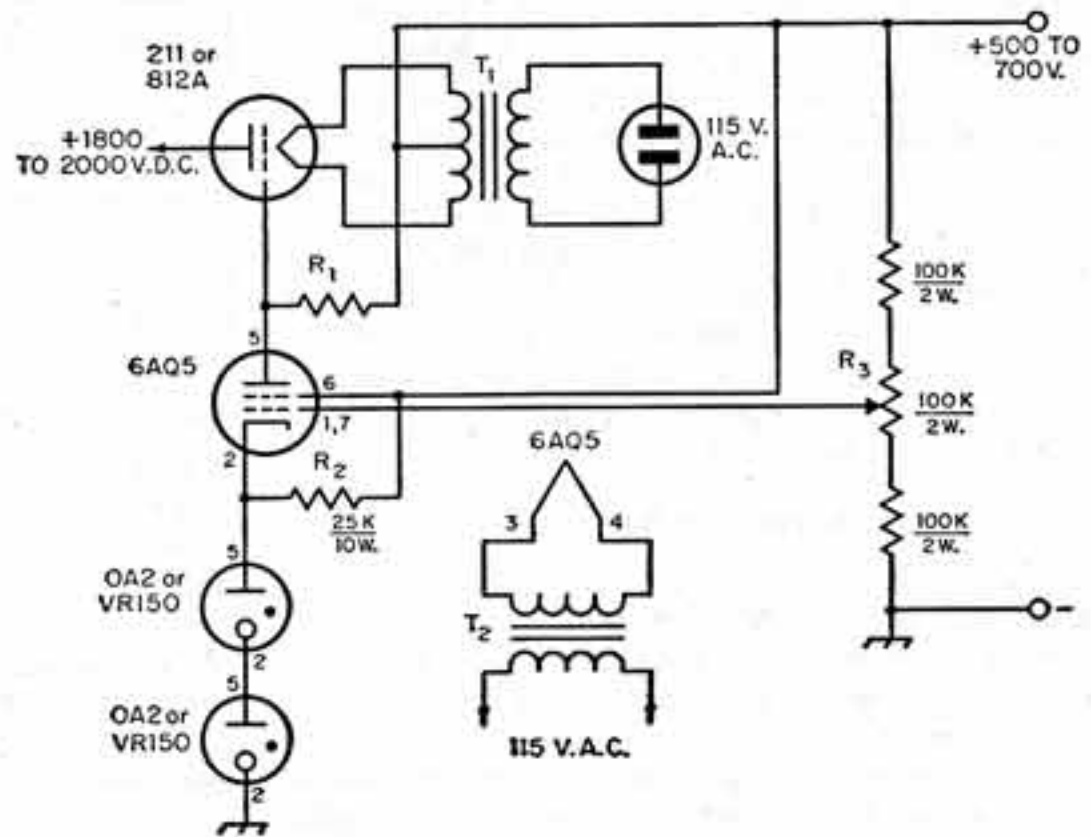

obtained with a regulation better than 1 per cent over a current range of 0 to 100 ma.

In the circuit of Fig. 7-26, a V-70D (or 8005) is used as the regulator, and the control tube is an 807 which can take the full output voltage, making it unnecessary to raise it above ground with VR tubes. If taps are switched on R_1 , the output voltage can be varied over a wide range. Increasing the screen voltage decreases the output voltage. For each position of the tap on R_1 , decreasing the value of R_3 will lower the minimum output voltage as R_2 is varied, and decreasing

the value of R_4 will raise the maximum output voltage. However, if these values are made too small, the 807 will lose control.

At 850 volts output, the variation over a current change of 20 to 80 ma. should be negligible. At 1500 volts output with the same current change, the variation in output voltage should be less than three per cent. Up to 88 volts of grid bias for a Class A or Class AB₁ amplifier may be taken from the potentiometer across the reference-voltage source. This bias cannot, of course, be used for biasing a stage that is drawing grid current.

A somewhat different type of regulator is the shunt regulator shown in Fig. 7-27. The VR tubes and R_2 in series are across the output. Since the voltage drop across the VR tubes is constant, any change in output voltage appears across R_2 . This causes a change in grid bias on the 811-A grid, causing it to draw more or less current in inverse proportion to the current being drawn by

Fig. 7-26—This regulator circuit used by W1SUN operates from the plate supply and requires no VR string. A small supply provides screen voltage and reference bias for the control tube.

Unless otherwise marked, resistances are in ohms.

($K = 1000$). Capacitors are electrolytic.

R_1 —50,000-ohm, 50-watt adjustable resistor.

R_2 —0.1-megohm 2-watt potentiometer.

R_3 —4.7 megohms, 2 watts.

R_4 —0.1 megohm, $\frac{1}{2}$ watt.

T_1 —Power transformer: 470 volts center tapped, 40 ma.; 5 volts, 2 amps.; 6.3 volts, 2 amps.

T_2 —Filament transformer: 7.5 volts, 3.25 amp. (for V-70D).

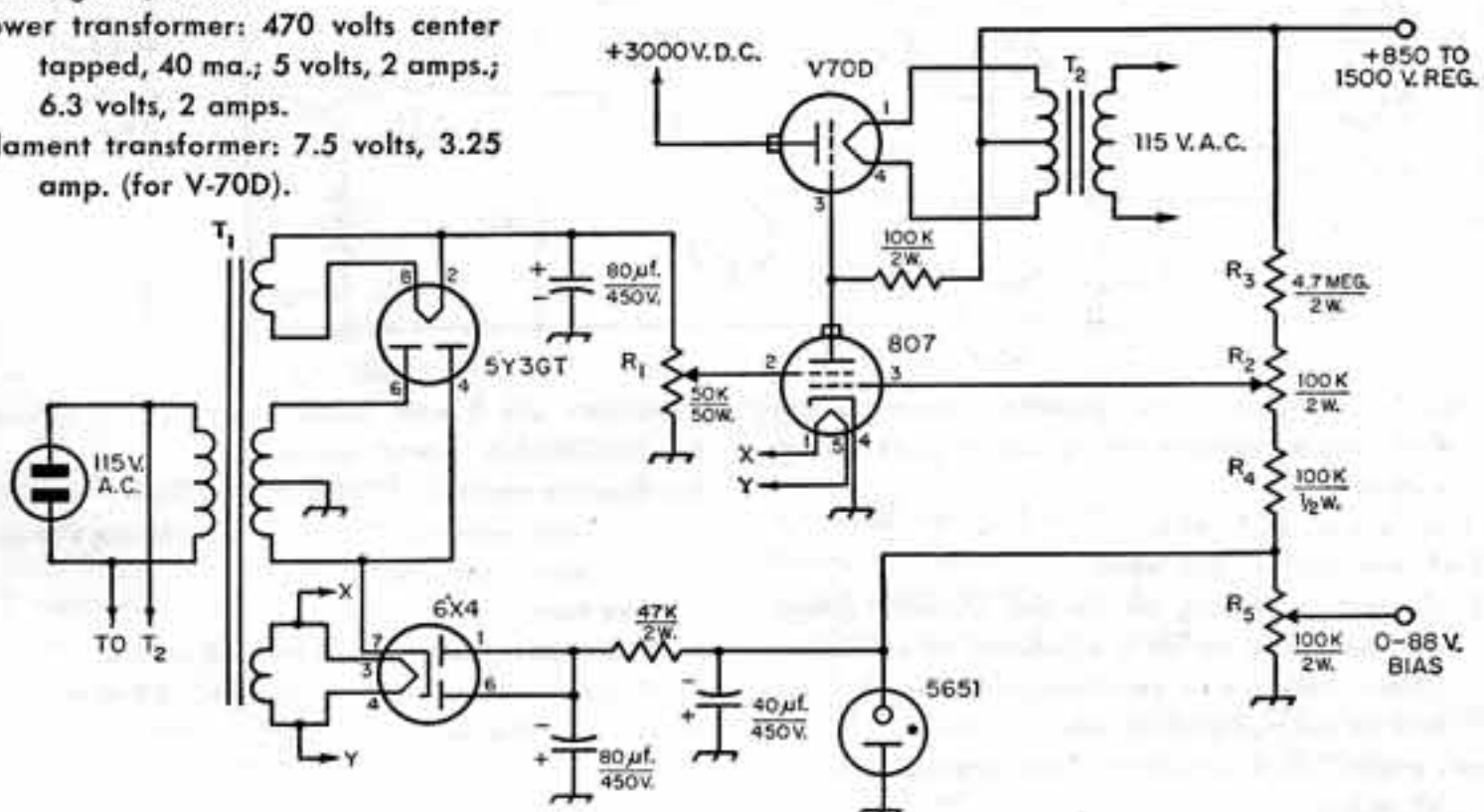

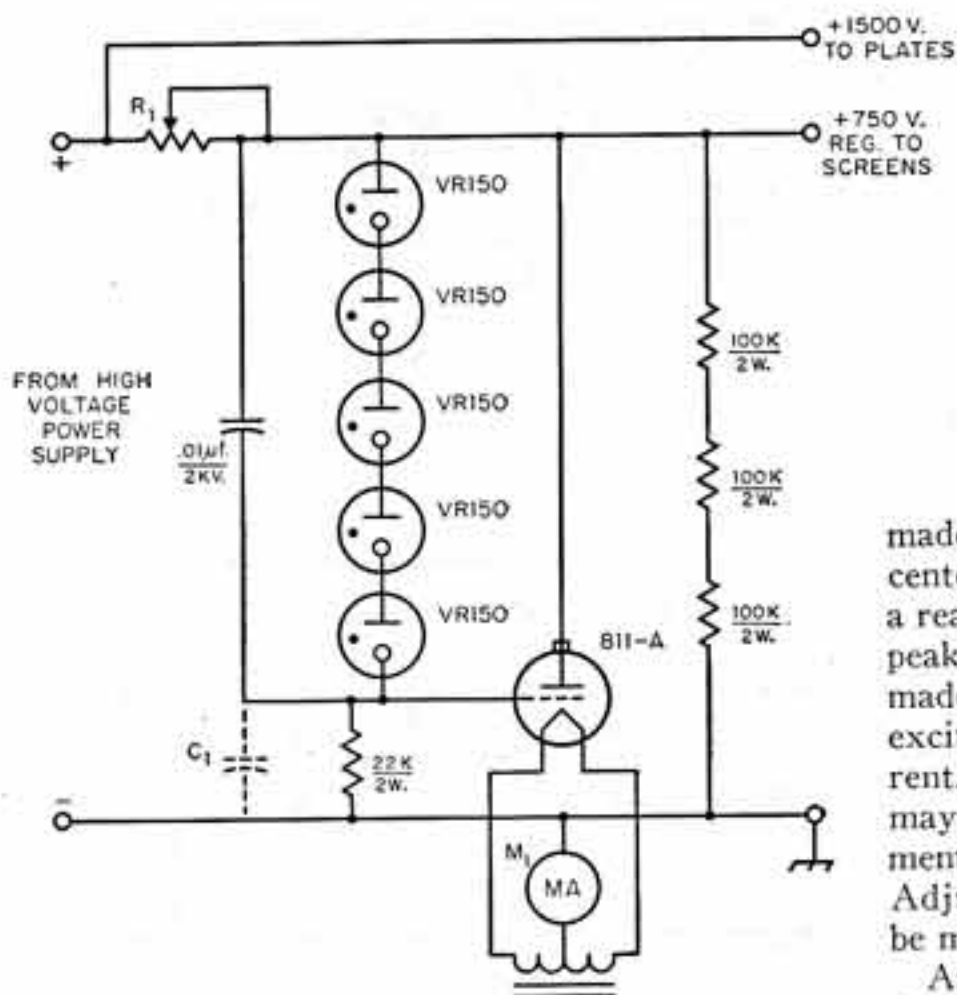

Fig. 7-27—Shunt screen regulator used by W2AZW.

C_1 —0.01 μ f., 400 volts if needed to suppress oscillation.

M_1 —See text.

R_1 —Adjustable wire-wound resistor, resistance and wattage as required.

the amplifier screen. This provides a constant load for the series resistor R_1 .

The output voltage is equal to the sum of the VR drops plus the grid-to-ground voltage of the 811-A. This varies from 5 to 20 volts between full load and no load. The initial adjustment is

made by placing a milliammeter in the filament center-tap lead, as shown, and adjusting R_1 for a reading of 15 to 20 ma. higher than the normal peak screen current. This adjustment should be made with the amplifier connected but with no excitation, so that the amplifier draws idling current. After the adjustment is complete, the meter may be removed from the circuit and the filament center tap connected directly to ground. Adjustment of the tap on R_1 should, of course, be made with the high voltage turned off.

Any number of VR tubes may be used to provide a regulated voltage near the desired value. The maximum current through the 811-A should be limited to the maximum plate-current rating of the tube. If larger currents are necessary, two 811-As may be connected in parallel. Over a current range of 5 to 60 ma., the regulator holds the output voltage constant within 10 or 15 volts.

BIAS SUPPLIES

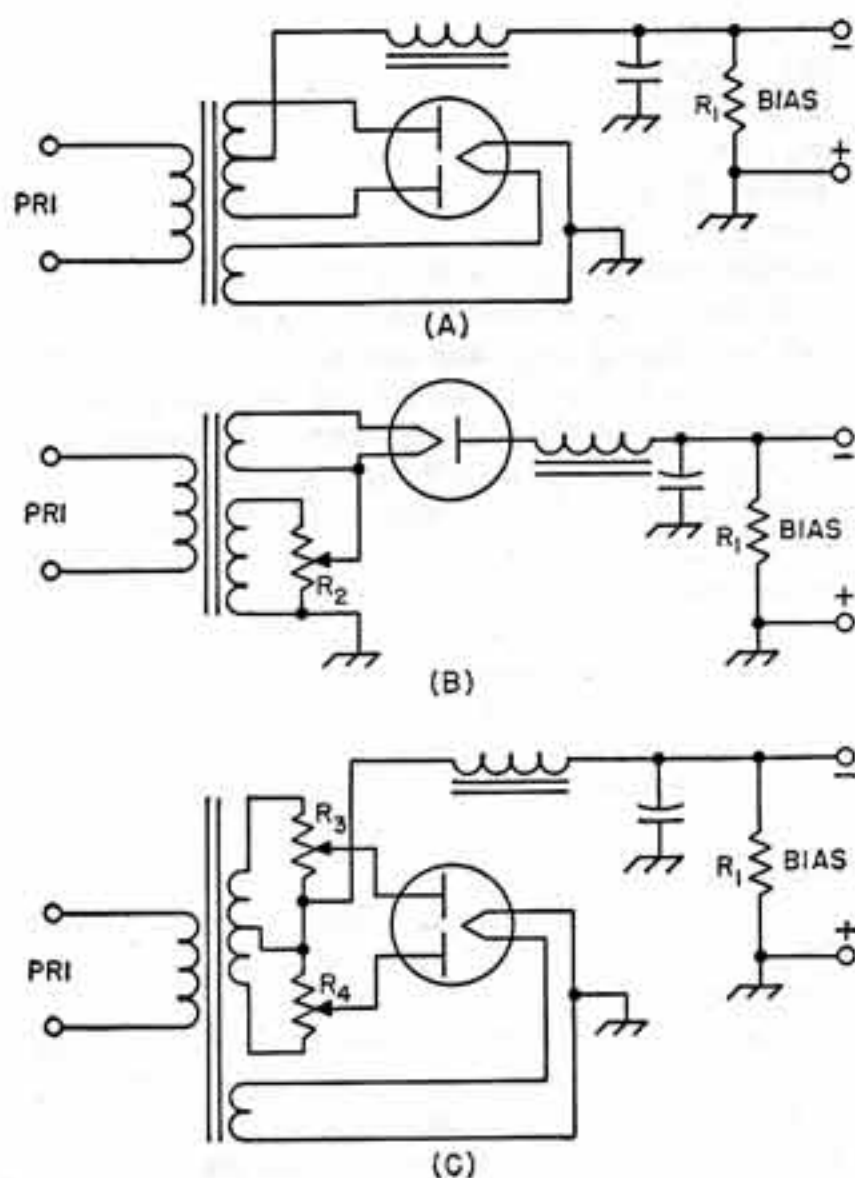

As discussed in Chapter 6 on high-frequency transmitters, the chief function of a bias supply for the r.f. stages of a transmitter is that of providing protective bias, although under certain circumstances, a bias supply, or pack, as it is sometimes called, can provide the operating bias if desired.

Simple Bias Packs

Fig. 7-28A shows the diagram of a simple bias supply. R_1 should be the recommended grid leak for the amplifier tube. No grid leak should be used in the transmitter with this type of supply. The output voltage of the supply, when amplifier grid current is not flowing, should be some value between the bias required for plate-current cut-off and the recommended operating bias for the amplifier tube. The transformer peak voltage (1.4 times the r.m.s. value) should not exceed the recommended operating-bias value, otherwise the output voltage of the pack will soar above the operating-bias value with rated grid current.

Fig. 7-28—Simple bias-supply circuits. In A, the peak transformer voltage must not exceed the operating value of bias. The circuits of B (half-wave) and C (full-wave) may be used to reduce transformer voltage to the rectifier. R_1 is the recommended grid-leak resistance.